

User Manual

BG500 Series Barrier Gate

Date: April 2022

Doc Version: 1.0

English

Thank you for choosing our product. Please read the instructions carefully before operation. Follow these instructions to ensure that the product is functioning properly. The images shown in this manual are for illustrative purposes only.



For further details, please visit our Company's website
www.zkteco.com.

Copyright © 2022 ZKTECO CO., LTD. All rights reserved.

Without the prior written consent of ZKTeco, no portion of this manual can be copied or forwarded in any way or form. All parts of this manual belong to ZKTeco and its subsidiaries (hereinafter the "Company" or "ZKTeco").

Trademark

ZKTeco is a registered trademark of ZKTeco. Other trademarks involved in this manual are owned by their respective owners.

Disclaimer

This manual contains information on the operation and maintenance of the ZKTeco equipment. The copyright in all the documents, drawings, etc. in relation to the ZKTeco supplied equipment vests in and is the property of ZKTeco. The contents hereof should not be used or shared by the receiver with any third party without the express written permission of ZKTeco.

The contents of this manual must be read as a whole before starting the operation and maintenance of the supplied equipment. If any of the content(s) of the manual seems unclear or incomplete, please contact ZKTeco before starting the operation and maintenance of the said equipment.

It is an essential pre-requisite for the satisfactory operation and maintenance that the operating and maintenance personnel are fully familiar with the design and that the said personnel have received thorough training in operating and maintaining the machine/unit/equipment. It is further essential for the safe operation of the machine/unit/equipment that personnel has read, understood and followed the safety instructions contained in the manual.

In case of any conflict between terms and conditions of this manual and the contract specifications, drawings, instruction sheets or any other contract-related documents, the contract conditions/documents shall prevail. The contract specific conditions/documents shall apply in priority.

ZKTeco offers no warranty, guarantee or representation regarding the completeness of any information contained in this manual or any of the amendments made thereto. ZKTeco does not extend the warranty of any kind, including, without limitation, any warranty of design, merchantability or fitness for a particular purpose.

ZKTeco does not assume responsibility for any errors or omissions in the information or documents which are referenced by or linked to this manual. The entire risk as to the results and performance obtained from using the information is assumed by the user.

ZKTeco in no event shall be liable to the user or any third party for any incidental, consequential, indirect, special, or exemplary damages, including, without limitation, loss of business, loss of profits, business interruption, loss of business information or any pecuniary loss, arising out of, in connection with, or relating to the use of the information contained in or referenced by this manual, even if ZKTeco has been advised of the possibility of such damages.

This manual and the information contained therein may include technical, other inaccuracies or typographical errors. ZKTeco periodically changes the information herein which will be incorporated into new additions/amendments to the manual. ZKTeco reserves the right to add, delete, amend or modify the information contained in the manual from time to time in the form of circulars, letters, notes, etc. for better operation and safety of the machine/unit/equipment. The said additions or amendments are meant for improvement /better operations of the machine/unit/equipment and such amendments shall not give any right to claim any compensation or damages under any circumstances.

ZKTeco shall in no way be responsible (i) in case the machine/unit/equipment malfunctions due to any non-compliance of the instructions contained in this manual (ii) in case of operation of the machine/unit/equipment beyond the rate limits (iii) in case of operation of the machine and equipment in conditions different from the prescribed conditions of the manual.

The product will be updated from time to time without prior notice. The latest operation procedures and relevant documents are available on <http://www.zkteco.com>.

If there is any issue related to the product, please contact us.

ZKTeco Headquarters

Address ZKTeco Industrial Park, No. 32, Industrial Road,
Tangxia Town, Dongguan, China.

Phone +86 769 - 82109991

Fax +86 755 - 89602394

For business-related queries, please write to us at sales@zkteco.com.

To know more about our global branches, visit www.zkteco.com.

About the Company

ZKTeco is one of the world's largest manufacturer of RFID and Biometric (Fingerprint, Facial, Finger-vein) readers. Product offerings include Access Control readers and panels, Near & Far-range Facial Recognition Cameras, Elevator/floor access controllers, Turnstiles, License Plate Recognition (LPR) gate controllers and Consumer products including battery-operated fingerprint and face-reader Door Locks. Our security solutions are multi-lingual and localized in over 18 different languages. At the ZKTeco state-of-the-art 700,000 square foot ISO9001-certified manufacturing facility, we control manufacturing, product design, component assembly, and logistics/shipping, all under one roof.

The founders of ZKTeco have been determined for independent research and development of biometric verification procedures and the productization of biometric verification SDK, which was initially widely applied in PC security and identity authentication fields. With the continuous enhancement of the development and plenty of market applications, the team has gradually constructed an identity authentication ecosystem and smart security ecosystem, which are based on biometric verification techniques. With years of experience in the industrialization of biometric verifications, ZKTeco was officially established in 2007 and now has been one of the globally leading enterprises in the biometric verification industry owning various patents and being selected as the National High-tech Enterprise for 6 consecutive years. Its products are protected by intellectual property rights.

About the Manual

This manual introduces the operations of **BG500 Series Barrier Gate**.

All figures displayed are for illustration purposes only. Figures in this manual may not be exactly consistent with the actual products.

Table of Contents

1	OVERVIEW	5
2	FEATURES AND FUNCTIONALITIES	5
3	APPEARANCE AND DIMENSIONS	6
4	SPECIFICATIONS	6
5	INSTALLATION PROCEDURE	7
5.1	INSTALLATION PRECAUTIONS	7
5.2	CABLE EMBEDDING	7
5.3	BOOM INSTALLATION	8
5.3.1	BOOM INSTALLATION PROCEDURE	8
5.3.2	INSTALLATION OF THE FOLDING BOOM	9
5.3.3	INSTALLATION OF THE FENCE BOOM ARM	10
6	DEFINITION OF LEFT AND RIGHT DIRECTIONS	11
7	MAINBOARD WIRING INSTRUCTIONS	11
7.1	CONNECTION WITH LPR CAMERA	12
7.2	CONNECTION WITH UHF CONTROLLER	13
7.3	CONNECTION WITH LOOP DETECTOR	13
7.4	CONNECTION WITH VR10 RADAR SENSOR	14
7.5	CONNECTION WITH INFRARED/PHOTOCELL DETECTOR	15
8	FUNCTION PARAMETER ADJUSTMENT INSTRUCTIONS	17
8.1	MAINBOARD PARAMETER SETTINGS	17
8.1.1	OPERATING PROCEDURE	17
8.2	PARAMETER SETTINGS DESCRIPTION	18
8.3	REMOTE CONTROL LEARNING INSTRUCTIONS	19
8.4	SET DELAY FOR AUTOMATIC CLOSING AFTER OPENING THE BOOM	20
9	BOOM BARRIER ADJUSTMENTS	21
9.1	HORIZONTAL AND VERTICAL ANGLE ADJUSTMENT OF BARRIER BOOM (MECHANICAL ADJUSTMENT)	21
9.2	DIRECTION INTERCHANGE OF THE BOOM ARM	22
9.3	SPRING ADJUSTMENT	22
10	PRODUCT PACKING LIST	23
11	TROUBLESHOOTING	24

1 Overview

The BG500 barrier gate uses a high-performance and safe low voltage DC brushless motor that provides stable and reliable operation, as well as digital coding control for quick and accurate response.

The all-in-one worm-gear reducer-transmission mechanism is easy to install and maintain, has a high load capacity and support install different types of barrier arm.

2 Features and Functionalities

- Highly energy-efficient because of the DC brushless motor.
- The modular structure makes it simple to maintain.
- Digital control mainboard with multiple configuration possibilities.
- Accurate and safe operation with the digital encoder.
- The barrier arm will rebound when an obstacle is being detected.
- Simple and compact transmission mechanism.
- Reversible boom direction.
- Adjustable angle of up/down.
- Manual move up and down in case of the absence of power.
- Adjustable opening and closing speed from 1.5s to 6s.
- Barrier arm's length from 3m to 6m.
- Various barrier arm.

3 Appearance and Dimensions

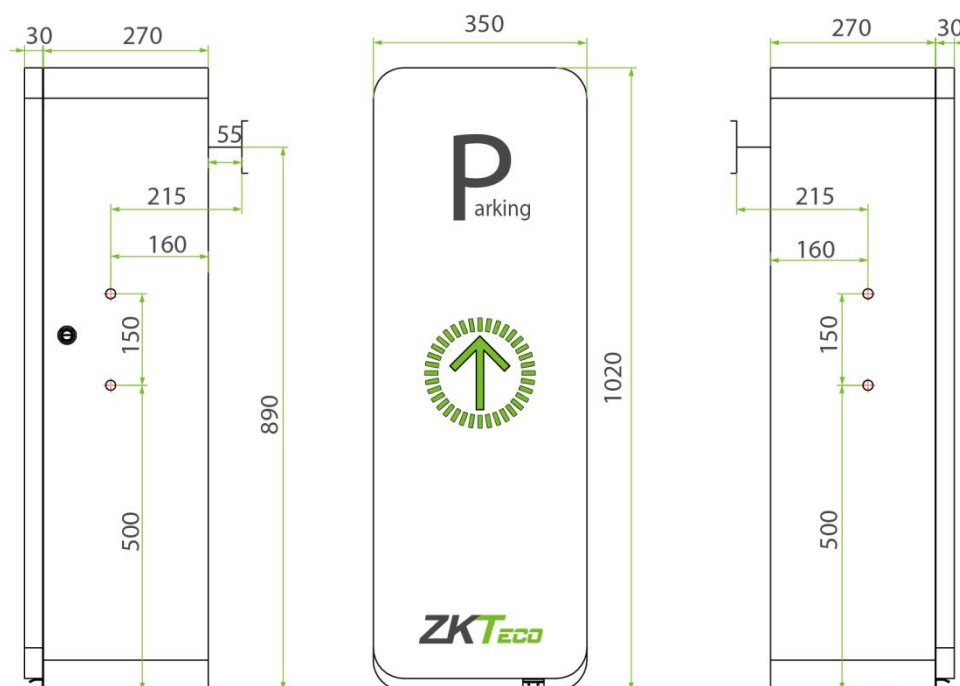

4 Specifications

Model	BG530 L/R	BG545 L/R	BG560 L/R	BG545 L/R-LED	BG545 L/R-90	BG545 L/R-F
Operating Speed	1.5s	2.5s	5s	2.5s	2.5s	2.5s
Boom Length	3m	4.5m	6m	4.5m	4.5m	4.5m
Boom Type	Straight boom	Telescopic boom		Straight boom with LED	Folding boom	Fence boom
Motor Type	DC 24V brushless motor					
Output Power	160W					
Output Current	10A					
Operating Voltages	DC 24V					
Power Supply	AC 220V/110V, 50Hz to 60Hz					
MCBF	2 million times					
Remote Control Distance	≥30m					
Operating Temperature	-30°C to 75°C					
Protection Level	IP54					
Chassis Dimension (W*L*H)	350*270*1020 (mm)					
Net Weight (excluding the barrier arm)	43 kg					

5 Installation Procedure

5.1 Installation Precautions

1. Install the parking barrier on a level ground. If the ground is not firm and level, a cement base is needed before the installation.
2. The length of the boom can be cut but cannot be increased. To establish new balance after cutting the boom length, the spring balance must be reset. The bottom of the spring has two plastic nuts for adjusting the new balance.
3. When the power is on, do not make any changes to the wire connections inside.
4. The GND should be connected to the cabinet for secure protection.

5.2 Cable Embedding

1. Prepare for a total of $\phi 25$ protective sleeve and cable in advance.
2. Connect the route cables through the protective sleeves.
3. Use a tool to open a cable tray on the ground.

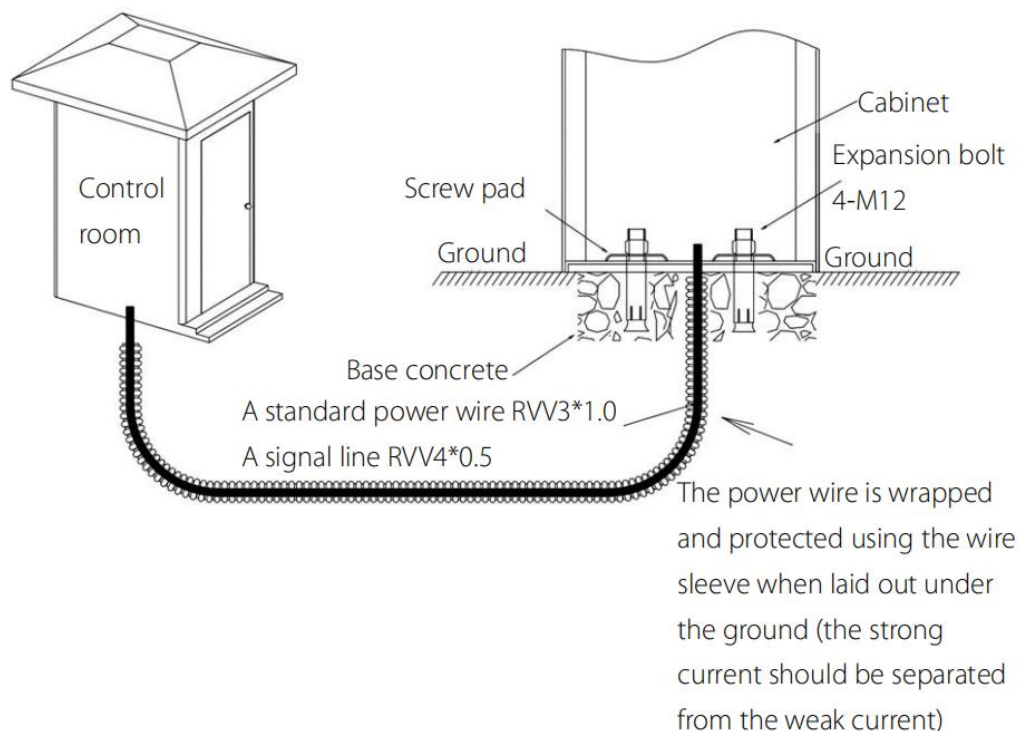

Dimensions

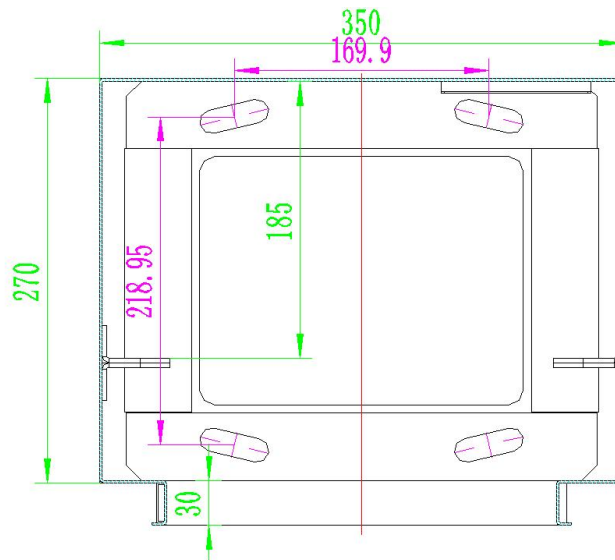

5.3 Boom Installation

5.3.1 Boom Installation Procedure

1. Pull the vice boom out from the main boom and install them with the two screws, as shown in Figure 1.
2. Install the boom to the chassis, as shown in Figure 2.

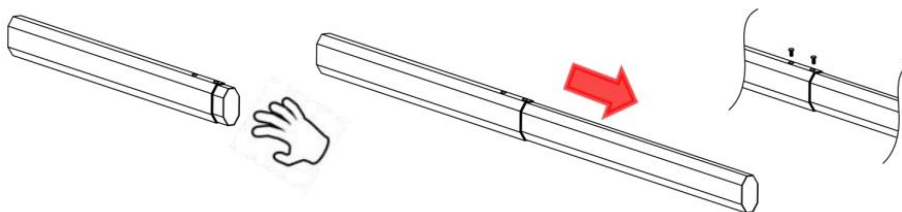

Figure 1 Connect the main boom with the vice together by 2 screws

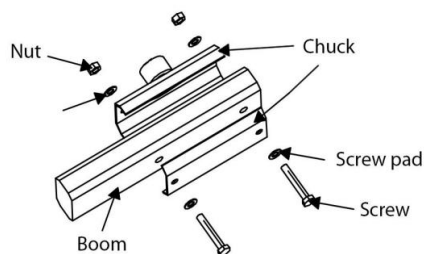
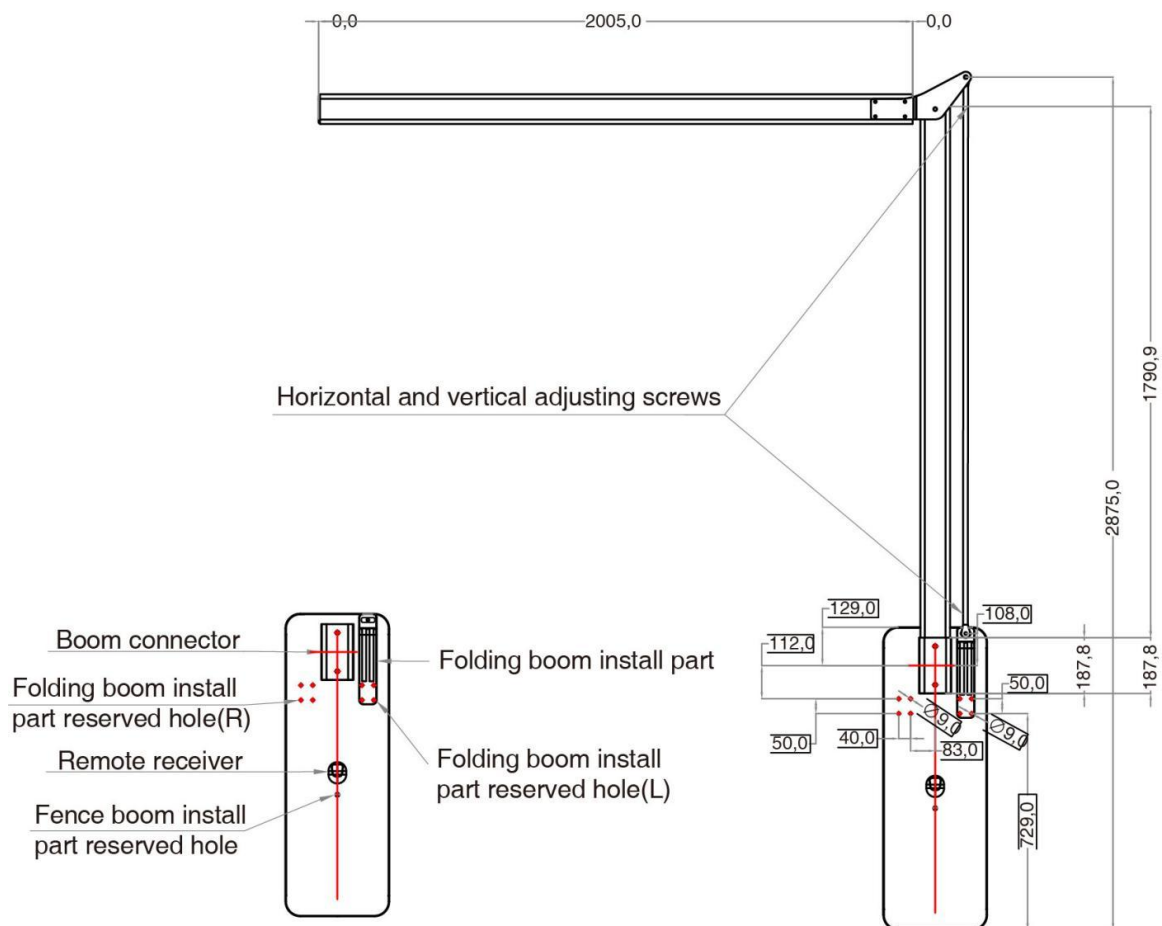

Figure 2 Installing the Boom to the Chassis

5.3.2 Installation of the Folding Boom



1. Install the folding boom assembly element after disconnecting the machine's power.
2. Fix the folding boom.
3. Adjust the vertical and horizontal position of the boom arm.
4. Start the power supply and observe the running state of the machine. If the boom arm open shaking, it is then necessary to loosen the spring and slow down the speed appropriately. It is also necessary to tighten the spring and slow down the speed accordingly if the boom arm closes shaking.

Note:

Default total height: $H \leq 2.8\text{m}$, Default total length: $L \leq 4.5\text{m}$ (Support customization, specify total height and total length in the order remarks)

5.3.3 Installation of the Fence Boom Arm

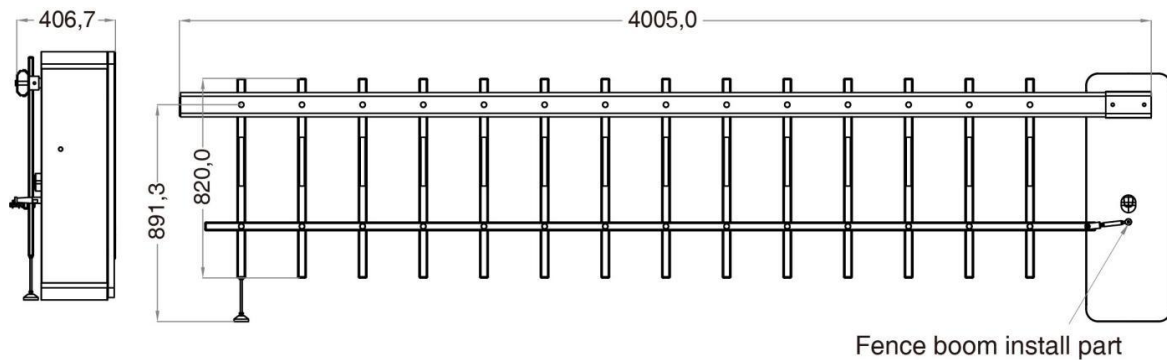

1. Install the fence boom install part after disconnecting the machine's power.
2. Fix the fence boom.
3. Adjust the vertical and horizontal position of the boom arm.
4. Start the power supply and observe the running state of the machine. If the boom arm open shaking, it is then necessary to loosen the spring and slow down the speed appropriately. It is also necessary to tighten the spring and slow down the speed accordingly if the boom arm closes shaking.

Notes:

- 1) Before the machine is energized to run the test, please make sure to install the barrier boom of the corresponding length for the test. If the barrier boom is not installed, please adjust, and remove the spring under the guidance of a professional person.
- 2) If the length of the barrier boom is cut and adjusted, the tightness of the spring and the position of the hanging hole must to adjusted accordingly in order to avoid the abnormal condition of the machine that cannot drop the boom.

6 Definition of Left and Right Directions

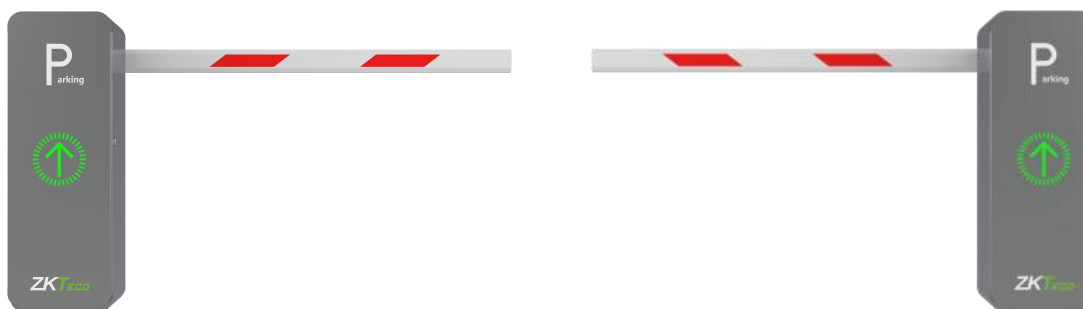

**L: The Chassis on the left,
the boom arm on the right.**

**R: The Chassis on the right,
the boom arm on the left.**

7 Mainboard Wiring Instructions

1. Please disconnect the power supply before wiring.
2. Please note that to switch the input voltage to 110V, you must set the DIP switch on the power supply to the following:

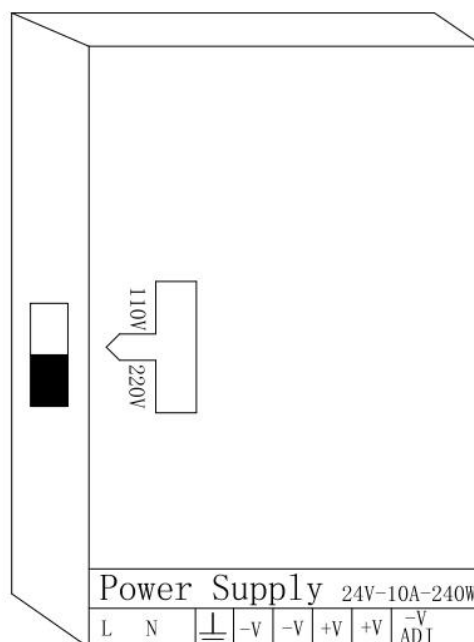

3. Make sure the terminals are securely fastened and the wiring is secure.
4. The wiring diagram of the control panel is explained as follows:

BG500 Wiring Diagram of Mainboard

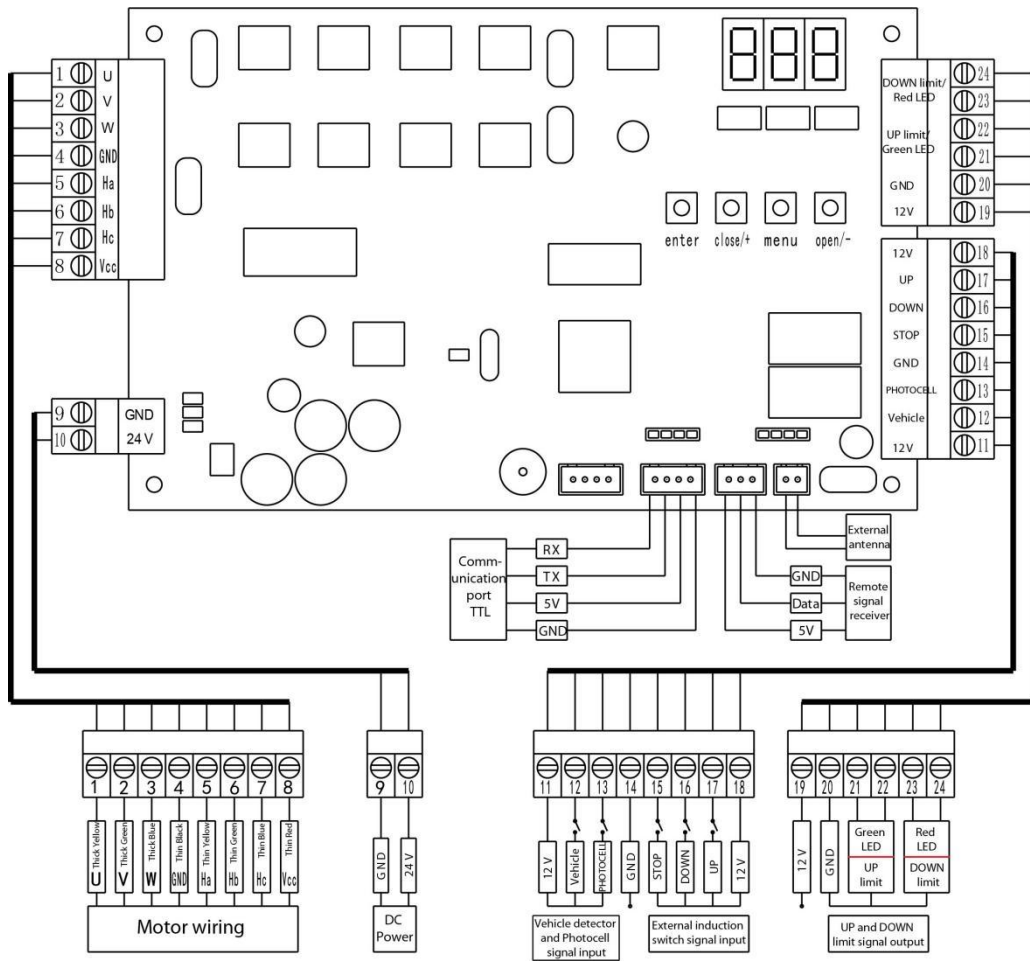

7.1 Connection with LPR Camera

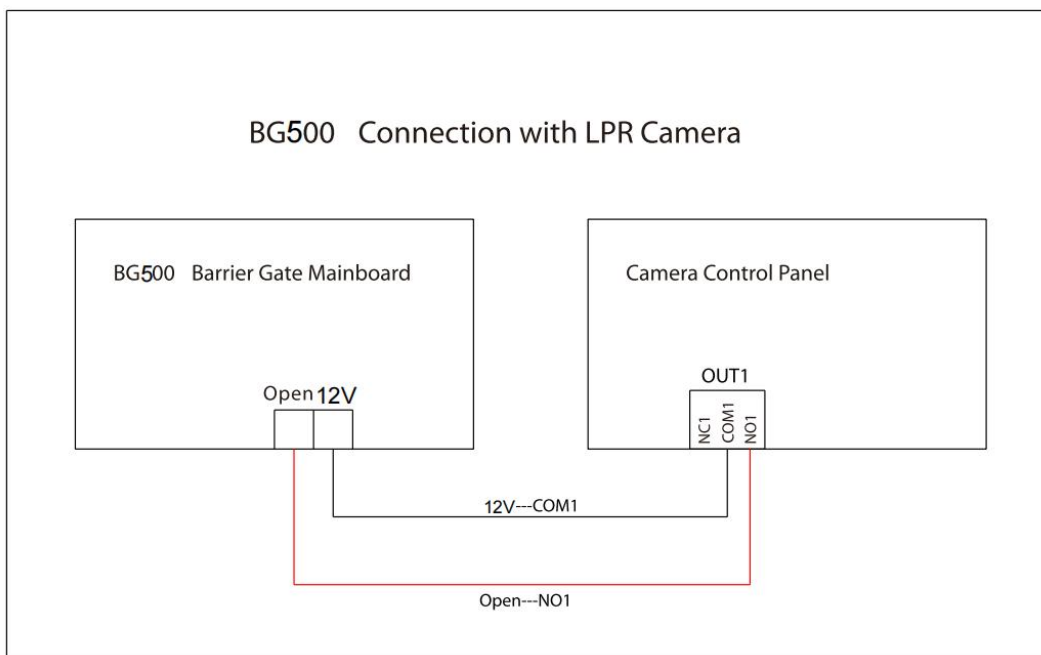

7.2 Connection with UHF Controller

(Note: The reader 1 and 2 of the inbio260 controller are corresponding to LOCK1, Reader 3 and 4 are corresponding to LOCK2)

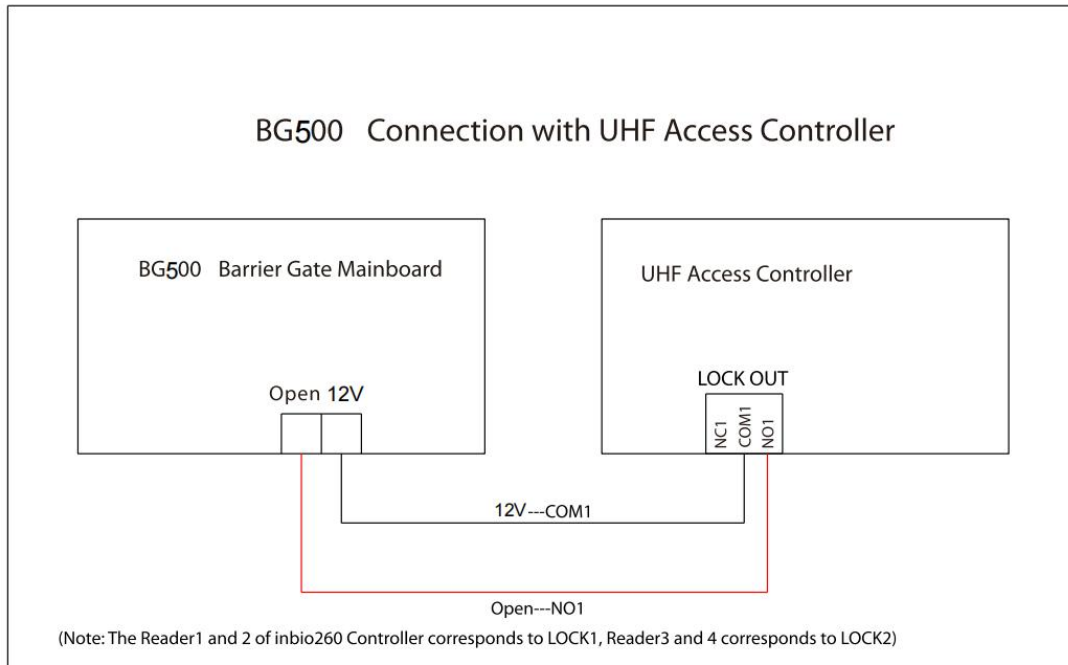

7.3 Connection with Loop Detector

Anti-smash and Auto-close function:

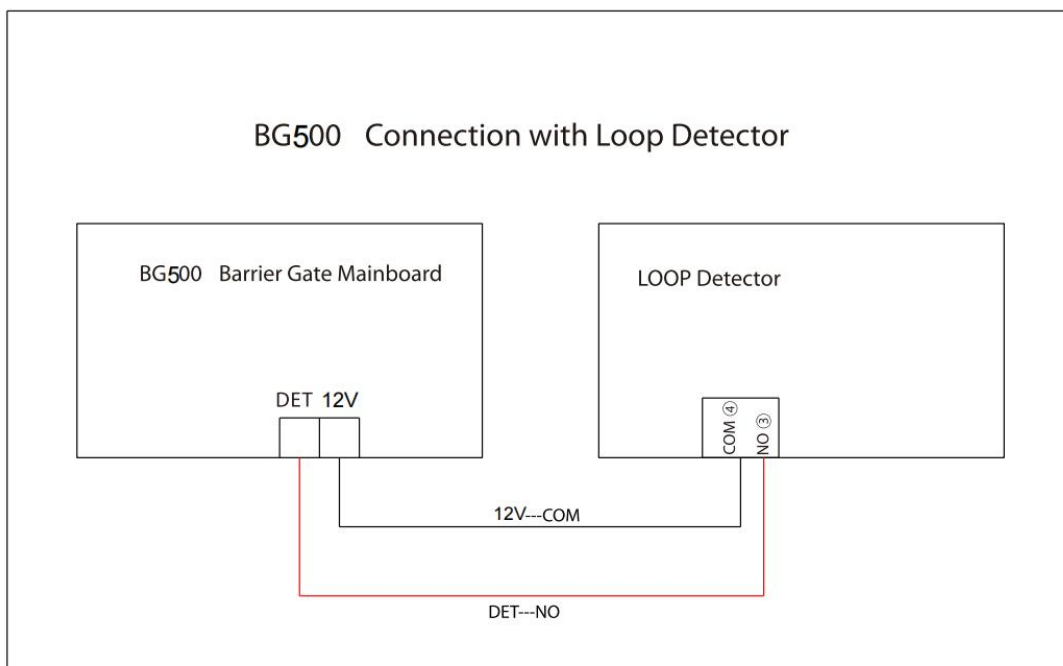

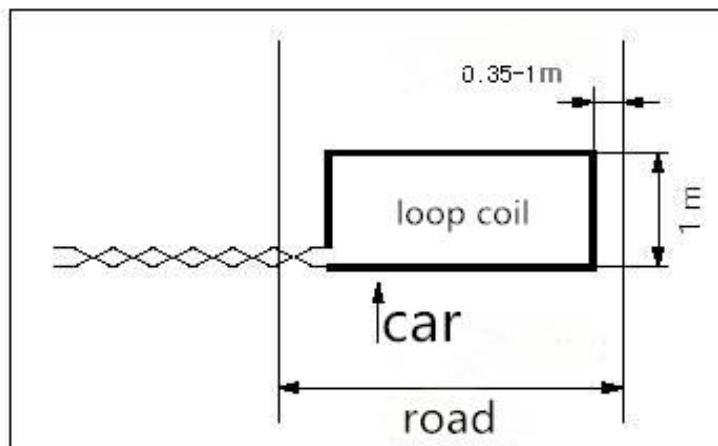

Coil Circumference	Coil Number
3m	Based on the requirements, ensure that the inductance is between 100μH to 200μH
3m to 6m	5 to 6 turns
6m to 10m	4 to 5 turns
10m to 25m	3 turns
25m	2 turns

7.4 Connection with VR10 Radar Sensor

Anti-smash and Auto-close function

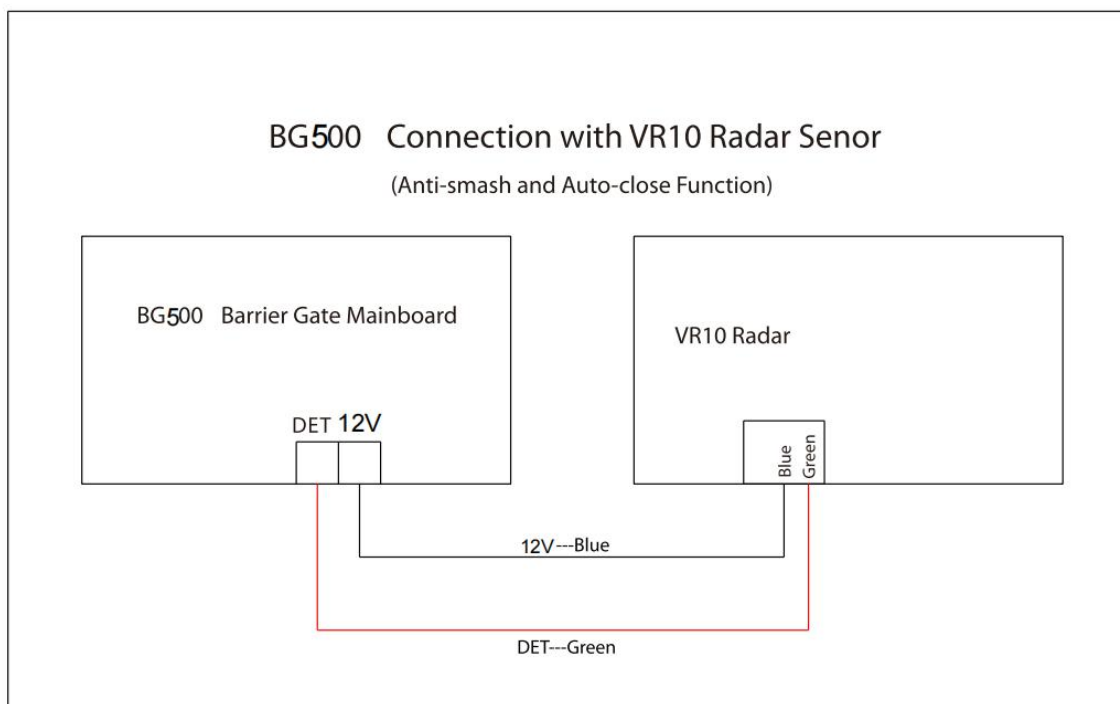

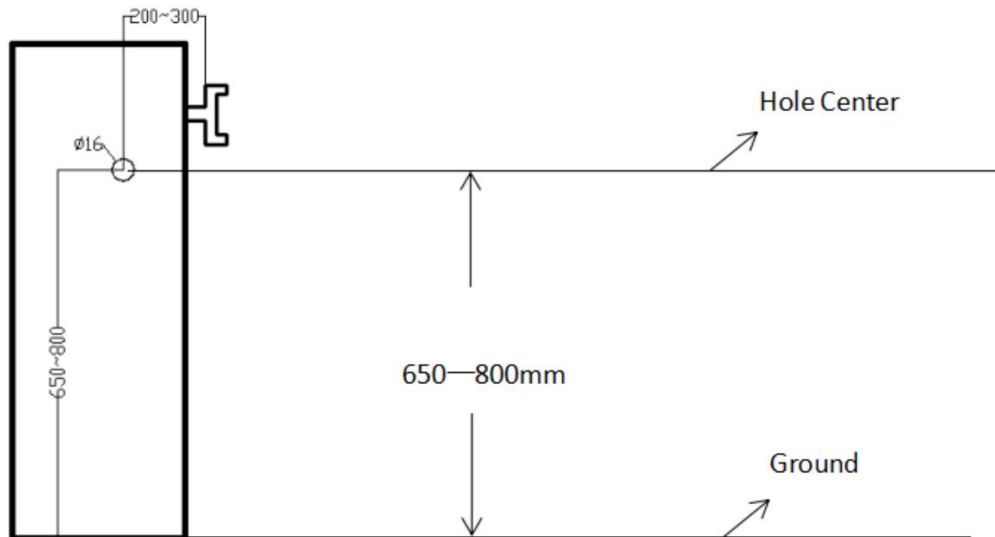

7.5 Connection with Infrared/Photocell Detector

Anti-smash function

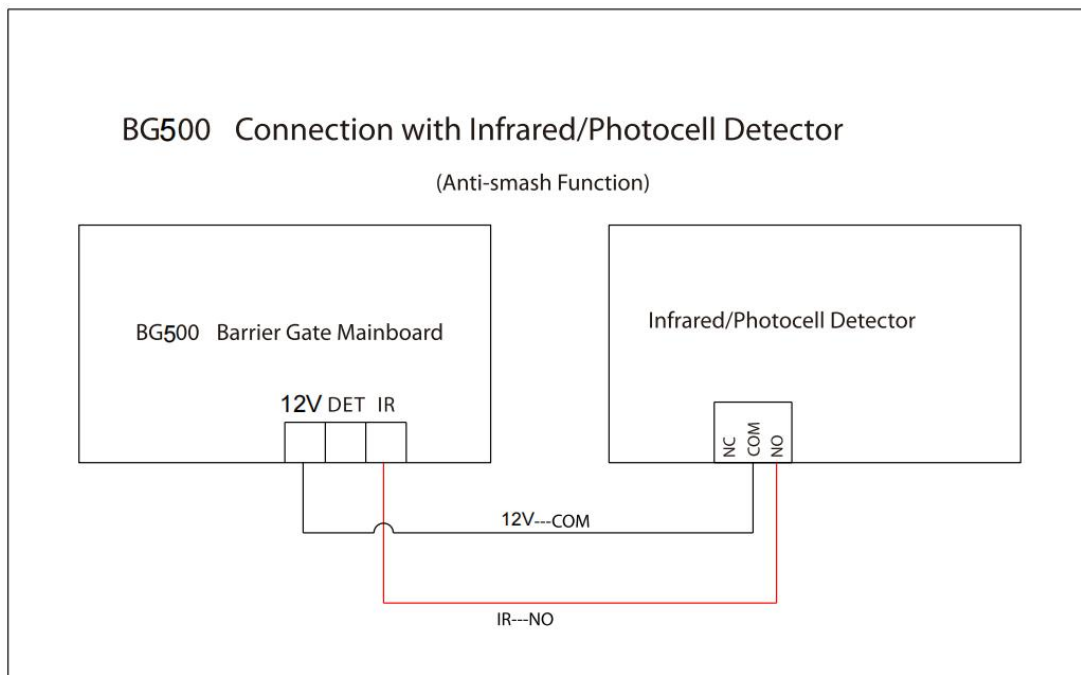

Anti-smash and Auto-close function

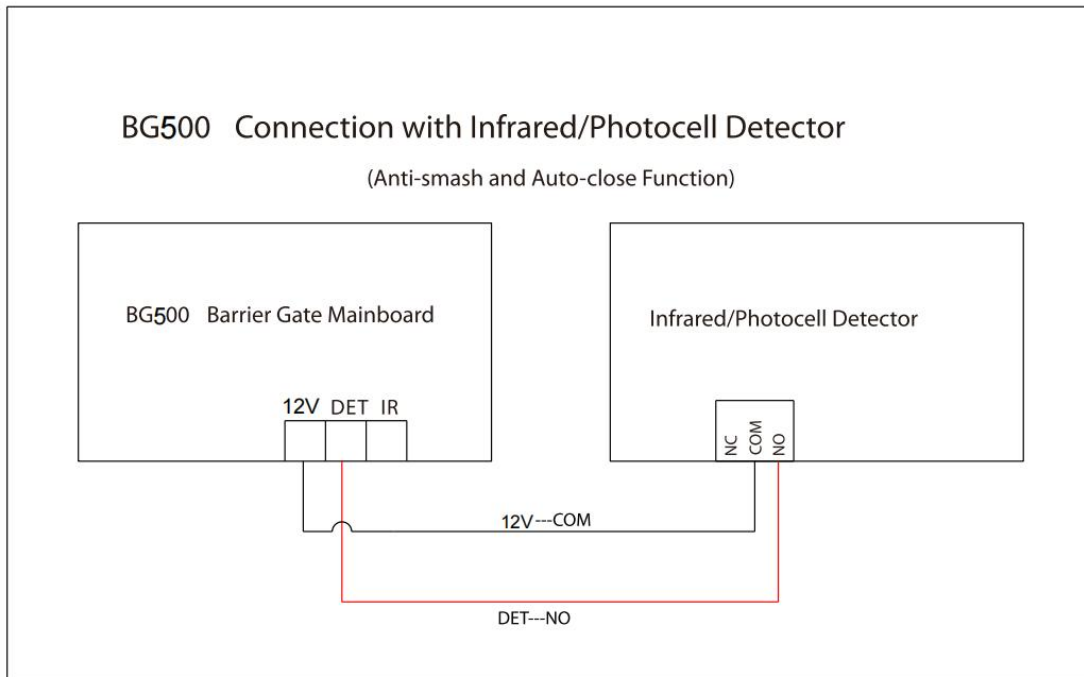

◆ Mounting height

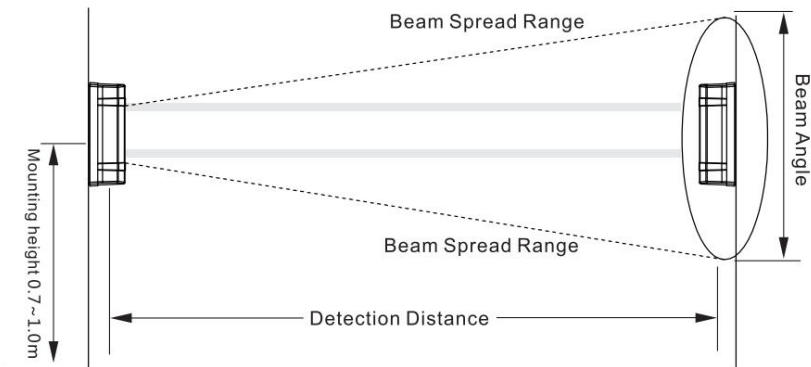

◆ Adjusting angle

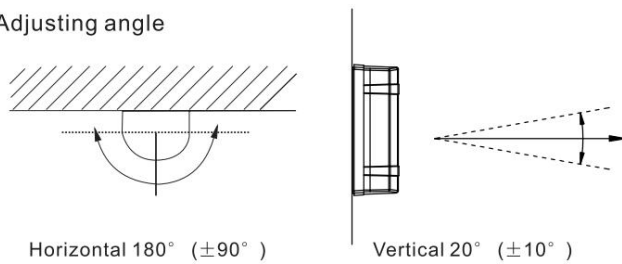

Notice: For best testing results, please avoid testing in 45°

8 Function Parameter Adjustment Instructions

After the initial installation and power-on, you must complete the self-check process and learn the opening and closing strokes by pressing the "on" and "off" buttons on the mainboard.

8.1 Mainboard Parameter Settings

Key Description

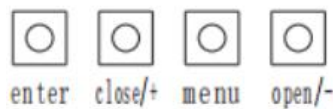
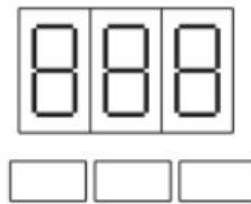

Menu: Menu options / Confirm and Enter

Enter: Confirm and Exit

Open/-: Decrease parameter/value

Close/+: Increase parameter/value

8.1.1 Operating Procedure

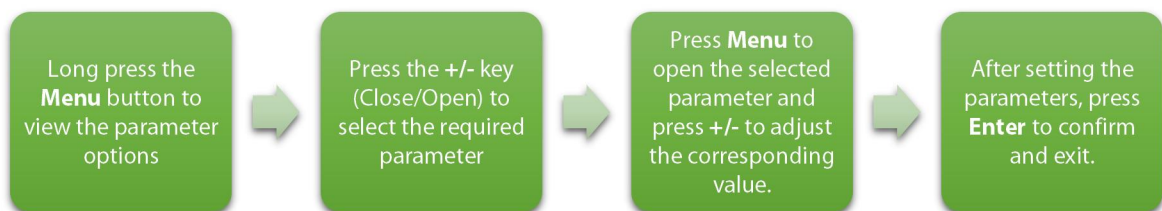

The display status is given below:

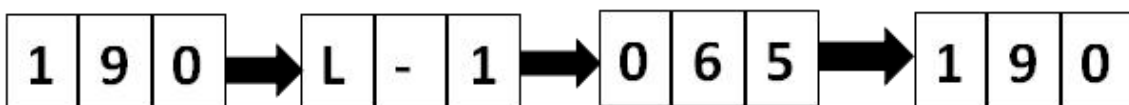

8.2 Parameter Settings Description

Parameter	List of menu items	3m boom parameter value	4.5m boom parameter value	6m boom parameter value
Opening speed adjustment: the larger the value, the faster the gate opening speed	L-1	80	60	60
Closing speed adjustment: the large the value, the faster the gate closing speed	L-2	70	50	50
Barrier boom in the place balance adjustment(default)	L-3	12	12	12
Anti-smashing car reaction time sensitivity adjustment(default)	L-4	30	30	30
Motor strength value Adjustment(default)	L-5	70	70	70
Horizontal adjustment of barrier boom	L-6	5	5	10
Test mode selection: 0 is manual,1 is automatic (default)	L-7	0	0	0
Turn on the memory function: 0 means no memory; 1 means memory and 4 indicates peak mode (default)	L-8	0	0	0
Vertical position adjustment of barrier boom	L-9	5	5	8
Adjusting the deceleration stroke of the first stage of opening barrier	L-L	40	40	30
Adjusting the deceleration stroke of the first stage closing barrier	L-B	40	40	30
Anti-smashing car force adjustment (default)	L-C	50	50	50
The forward and reverse running settings of the barrier type,1 is L and 2 is R (factory setting)	L-D	0 or 3	0 or 3	0 or 3
Start motor strength value of gate (default)	L-E	30	30	30
Remote learning function: 000 is the learning state; 253 is the automatic deletion of the remote control	L-F	0	0	0

Adjustment of the deceleration stroke for the second section of the barrier opening (default)	L-H	0	0	0
Adjustment of the deceleration stroke of the second barrier closing	L-P	21	21	21
Traffic light mode adjustment	L18	0	0	0
Ground sensing delay to drop the boom: 0 means the function is disabled, 1 to 255 is the time corresponding to the delay (need to cooperate with the ground sensing system)	L-19	0	0	0
Automatic boom-dropping adjustment after starting delay: ss 0 means that function is disabled, 1 to 255 is the time corresponding to delay automatic boom falling	L-20	0	0	0

8.3 Remote Control Learning Instructions

- 1. Remote Control Pairing:** Long press the **Menu**, then press +/- to select L-F [L15]. Press the **Menu** again to set the parameter value. At this time, the LED display value is "000", and then press any button on the remote control until you hear a beep sound from the Mainboard. If the pairing is successful, it will automatically return to the menu option. Press **Enter** to exit the menu.

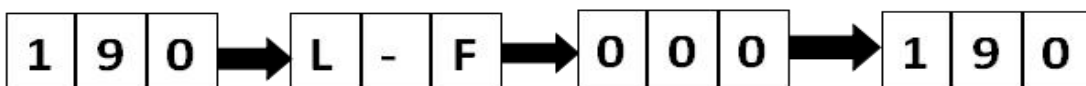

- 2. Delete Remote Control Pairing:** Long press the **Menu**, then press +/- to select L-F [L15]. Press the **Menu** again to set the parameter value, and then set the parameter value to "253". At this time, it will automatically return to the menu, indicating that all the remote controls have been deleted.

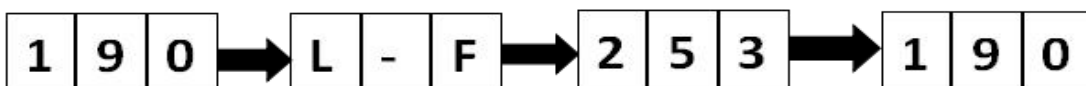

8.4 Set Delay for Automatic Closing after Opening the Boom

Long press the **Menu** button, then press +/- to select the L20 parameter, and then press the **Menu** to set the parameter value after selection. At this time, the display will be 000 i.e., in the disabled state. Set the delay value as per the requirements. Finally, press **Enter** to exit the menu. For example, if it is set to "005", the machine will automatically close after 5 seconds after opening the barrier.

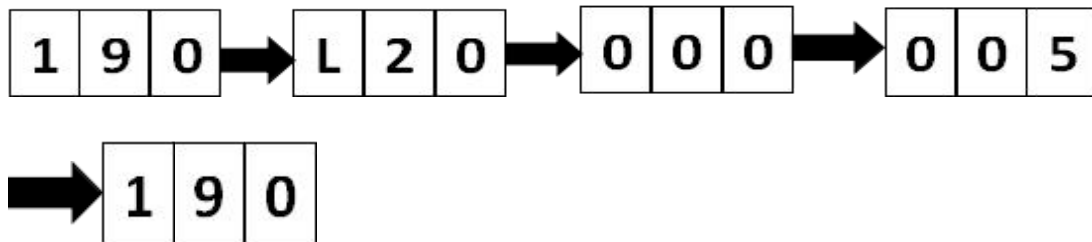

9 Boom Barrier Adjustments

9.1 Horizontal and Vertical Angle Adjustment of Barrier Boom (Mechanical Adjustment)

Note: The horizontal and vertical angles of the barrier boom have been adjusted before leaving the factory. Please do not adjust them without the guidance of professionals to avoid any mechanical damage.

1. Adjust the horizontal position of the barrier boom

The connecting boom crank will be an overlapping structure, and the two rotation points of the connecting boom are coincident with the output shaft of the reducer at 3 points and a line. This is the horizontal position of the barrier boom. If you find that the barrier boom is not in level or inclined at this time, then loosen the 2 screws of the spindle connecting arm, turn the barrier boom to the level, and then tighten the screws.

2. Adjust the vertical position of the barrier boom (adjusted by mechanical structure)

The connecting boom crank is in an unfolded shape, and the two rotation points of the connecting boom and the output shaft of the reducer are in an unfolded 3-point line. This is the vertical position of the barrier boom. If it is found that the barrier boom is not in the vertical position and is inclined at this time, then loosen the 2 screws of the rocker (rocker-arm), then turn the barrier boom to the vertical, and tighten the screws.

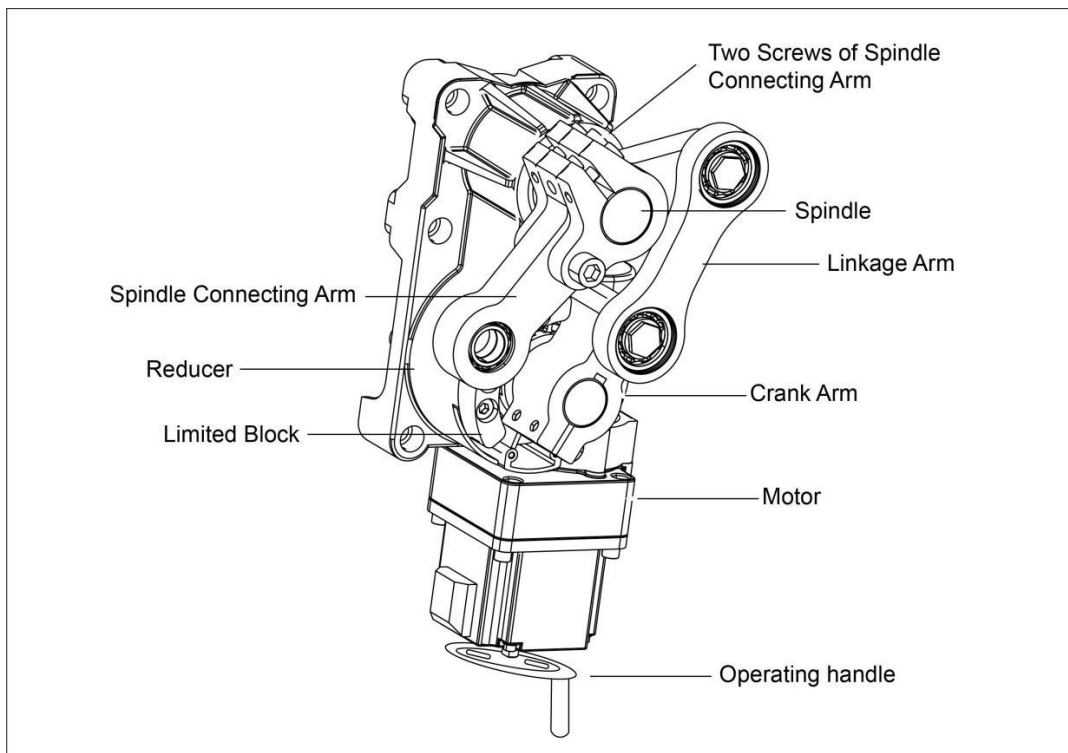

9.2 Direction Interchange of the Boom Arm

For example, when L is changed to R, the operation steps are as follows:

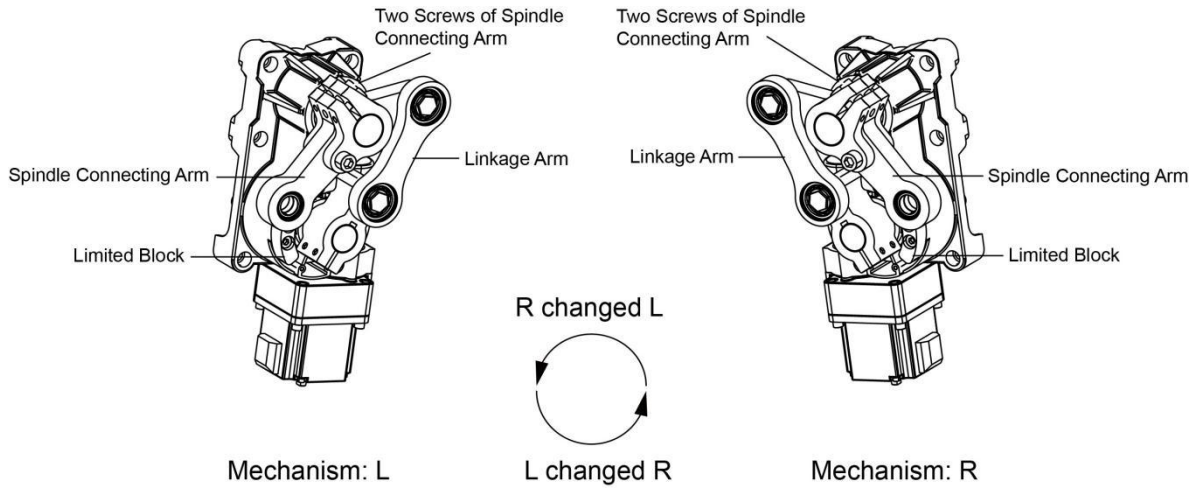

1. Please turn off the electricity before starting. Remove the spring, spring hanging arm, and boom.
2. Change the direction of the Spindle Connecting Arm and the linkage Arm.
3. Turn the Limited Block to the other direction.
4. After the mechanical operation, you need to set the movement parameter L-D on the motherboard, such as changing from L to R, then the value of this parameter should be set from 0 to 3.

9.3 Spring Adjustment

If the boom arm shakes when it rises, then you can adjust the spring loosely, and if the boom arm shakes when it falls, you can adjust the spring tightly.

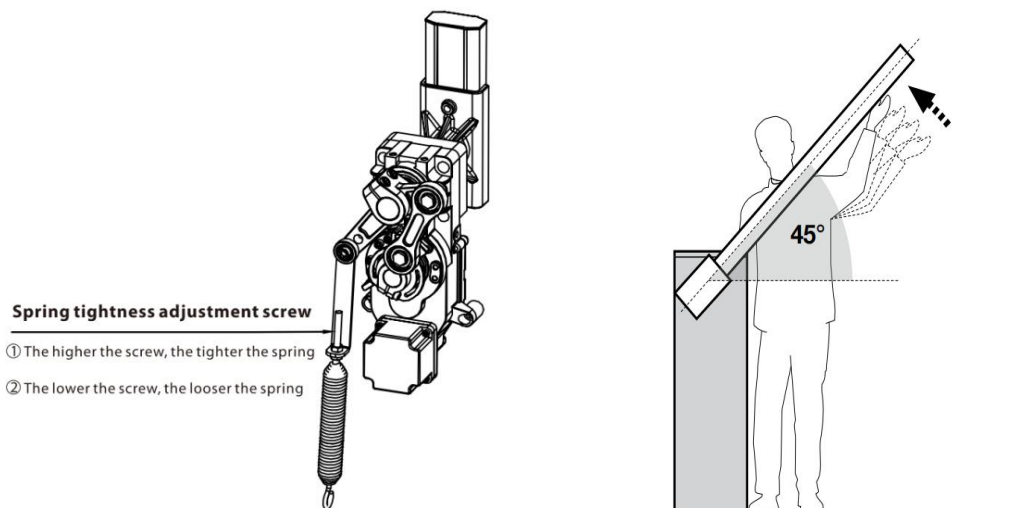

1. The best balance is when the barrier boom is at 45°.
2. The spring wire diameter is adapted to different boom lengths: 3m boom with $\phi 4.5\text{mm}$; 4.5m boom with $\phi 5.5\text{mm}$ and 6m boom with $\phi 6.5\text{mm}$. (If the boom is too short (less than 2m), do not install the spring).

10 Product Packing List

Material	Quantity
User manual	1
Chassis Explosion Screw M12X140	4
Key	2
Boom pressure plate	1
Chassis pressure plate	2
Wireless remote	2
Barrier boom hexagon bolt M10X70	2
Barrier boom	1
Machine	1

11 Troubleshooting

SN	Trouble Description	Cause	Solution
1	The Power Supply has a 24V output, but the mainboard power indicator does not light up.	<ol style="list-style-type: none"> 1. 24V output wiring might be reversed 2. The mainboard might work abnormally 3. Loose wiring 	<ol style="list-style-type: none"> 1. Swap the DC output wiring 2. Replace the Mainboard 3. Tighten the wiring
2	The AC input is normal, but the power indicator is off.	<ol style="list-style-type: none"> 1. The power fuse might be blown 2. Abnormal power supply 3. Loose wiring 	<ol style="list-style-type: none"> 1. Replace the fuse 2. Replace the power supply 3. Tighten the wiring
3	The power indicator is on, the landing boom indicator is normal, and the motor is not running.	<ol style="list-style-type: none"> 1. The motor wiring might be wrongly connected, or the wiring is loose 2. The internal encoder of the motor may work abnormally 3. The motor stroke limit exceeds the position 	<ol style="list-style-type: none"> 1. Check the wiring according to the wiring diagram, and tighten the wiring if required 2. Reconnect the motor wire 3. Re-adjust the motor limit parameters
4	The remote-control buttons do not respond.	<ol style="list-style-type: none"> 1. The remote control is not using ZKTeco brand, or it is from another model 2. The remote control does not match 3. The remote control or the receiver is damaged 4. The remote-control battery is completely discharged 	<ol style="list-style-type: none"> 1. Confirm to use ZKTeco brand and its applicable models for remote control 2. Rematch remote control 3. Replace the remote control or the receiver 4. Replace the remote-control battery
5	The boom cannot be closed normally after the machine is being powered on	<ol style="list-style-type: none"> 1. The barrier gate is not installing the barrier boom, so the motor cannot be closed due to the strong pull of the spring 2. The length of the installed boom is too short, and the spring is too tight 	<ol style="list-style-type: none"> 1. Install the boom normally or remove all the spring 2. Adjust the spring according to the length of the boom
6	The loop detector signal is not working	<ol style="list-style-type: none"> 1. Wrong signal wiring 2. Install loop coil with few or too many turns 3. Detector damage 	<ol style="list-style-type: none"> 1. Connect according to the wiring diagram 2. Calculate the circumference of the loop coil according to the width of the lane, and then confirm the number of turns install 3. Replace new loop detector

7	The radar detector signal is not working	<ol style="list-style-type: none"> 1. Wrong signal wiring 2. Distance and environment learning is not correct 3. Detector damage 	<ol style="list-style-type: none"> 1. Connect according to the wiring diagram 2. Complete the installation test through the radar installation video or the user manual 3. Replace new radar detector
8	Abnormal shaking of the barrier boom occurred while opening and closing	Spring too tight or too loose and the running speed too fast	If the boom arm open shaking, it is necessary to loosen the spring and slow down the speed appropriately; If the boom arm close shaking, it is necessary to tighten the spring and slow down the speed appropriately.
9	The boom is not vertical and parallel after opening or closing	<ol style="list-style-type: none"> 1. The spindle is not properly calibrated 2. Encoder travel limit error 	<ol style="list-style-type: none"> 1. Loosen the screw on the spindle connecting arm and then adjust and calibrate the spindle direction 2. Adjust travel limit parameters again
10	Abnormal sound is heard when the motor is running	<ol style="list-style-type: none"> 1. Motor rotor bearing is being damaged 2. Operating handle broken 	<ol style="list-style-type: none"> 1. Replace new motor 2. Replace the new operating handle

ZKTeco Industrial Park, No. 32, Industrial Road,

Tangxia Town, Dongguan, China.

Phone : +86 769 - 82109991

Fax : +86 755 - 89602394

www.zkteco.com



Copyright © 2022 ZKTECO CO., LTD. All Rights Reserved.